



**LTPC**<sup>®</sup>  
恒敏灵通气动

宁波恒敏灵通气动成套有限公司

NINGBO HENGMIN LINGTONG PNEUMATIC COMPONENTS&SET CO.,LTD

地址:浙江省宁波市溪口镇公棠工业区 P. C: 315501

ADD: Gongtang Industrial Zone, Xikou, Ningbo, Zhejiang, China

TEL: +86-574-88850982

FAX: +86-574-88853982

Http://www.ltqd.com

E-mail: sales@ltqd.com



官网



公众号

[www.ltqd.com](http://www.ltqd.com)

2019



## 企业简介 Enterprise Profile

宁波恒敏灵通气动成套有限公司(LTPC)是一家专业生产气动产品企业。公司从事生产气动产品有20年的历史。目前公司已经发展成为厂房面积18000平方米,拥有日本进口加工中心、数控车床、数控全自动电磁阀生产线等几十台先进生产设备。公司设有宁波市级“气动产品研发中心”,11年被评为“为宁波高新技术企业”,11年被认定为“浙江省工商企业信用AA级”。公司本着“以质量求生存,以信誉赢客户”的经营态度,以“至诚为道,至仁为德”的企业理念深受客商信任。业务遍及中国各地,并出口东南亚、中东、欧美等国家。

公司技术设备先进、检测手段完善、产品款式多样、质量可靠。主要产品有气源处理元件、控制元件、气动执行元件、辅助元件以及成套系统,广泛应用于机械、冶金、食品、包装、纺织、电子等行业。公司于2000年通过ISO9001:2000国际质量体系认证及CE认证,严格按照质量体系运行。本公司擅长于根据客户要求设计制造各类特殊气动产品,以满足不同客户需求。

恒敏灵通企业深知,未来的世界是品牌的世界,品牌来自于创新。随着企业的发展壮大,与此同时,公司还和西安交通大学机械学院合作,这大大地增强了恒敏灵通企业的研发能力。相信不久的将来,我们会和更多的优秀学院和客户合作,走自主创新的品牌之路。

公司坐落于国家AAAAA级风景名胜,浙江省宁波市奉化溪口镇,交通便捷,景色秀丽。竭诚欢迎新老客户光临惠顾,并携手共创新世纪辉煌业绩。

Ningbo Hengmin Lingtong Pneumatic Components & Set Co., Ltd (LTPC). Has been engaged in production of industrial component for more than 20 years. Our company has developed into a plant area of 18,000 square meters and introduced Japan machining center, CNC lathe, CNC automatic solenoid valve production lines and dozens of advanced production equipments. The Company has a pneumatic product research and development center in Ningbo city. Our company has won many honors for, such as "high-tech enterprises of Ningbo", "Zhejiang business credit AA level" and so on. Based on the principle "quality guarantees existence, prestige wins customers", our company has won the hearts of plenty of customers. There are markets across the whole country, even our markets have reached Southeast Asia, Middle East, Europe, the United States and other countries.

In addition, the company has advanced technology and equipments, perfect detection means, various products with reliable quality. The main products are pneumatic components, air source treatment units, air filter combinations, filters and regulators, all kinds of valves, cylinders, and pneumatic accessories. Which are widely used in machinery, metallurgy, food, packaging, textile, electronics and other industries. In 2000 our company won ISO 9001: 2000 international quality system certification and CE certification. The company is specialized in the design and manufacture of various types of special pneumatic products to meet different customer needs based on customer requirements.

Our company has a deep understanding that the brand will become more and more important in future. With the development and growth of the enterprise, at the same time, cooperation with Mechanical College of Xi'an Jiaotong University, our company's R & D capabilities have been greatly enhanced. We believe that in the near future, we will be on the road to the creation of brand through cooperating with more excellent colleges and clients.

Our company is located in Xikou, the national AAAA level scenic spots, which has convenient transportation and beautiful scenery. We sincerely welcome new and old customers and work together to create brilliant future.



## 企业荣誉 Company Rewards

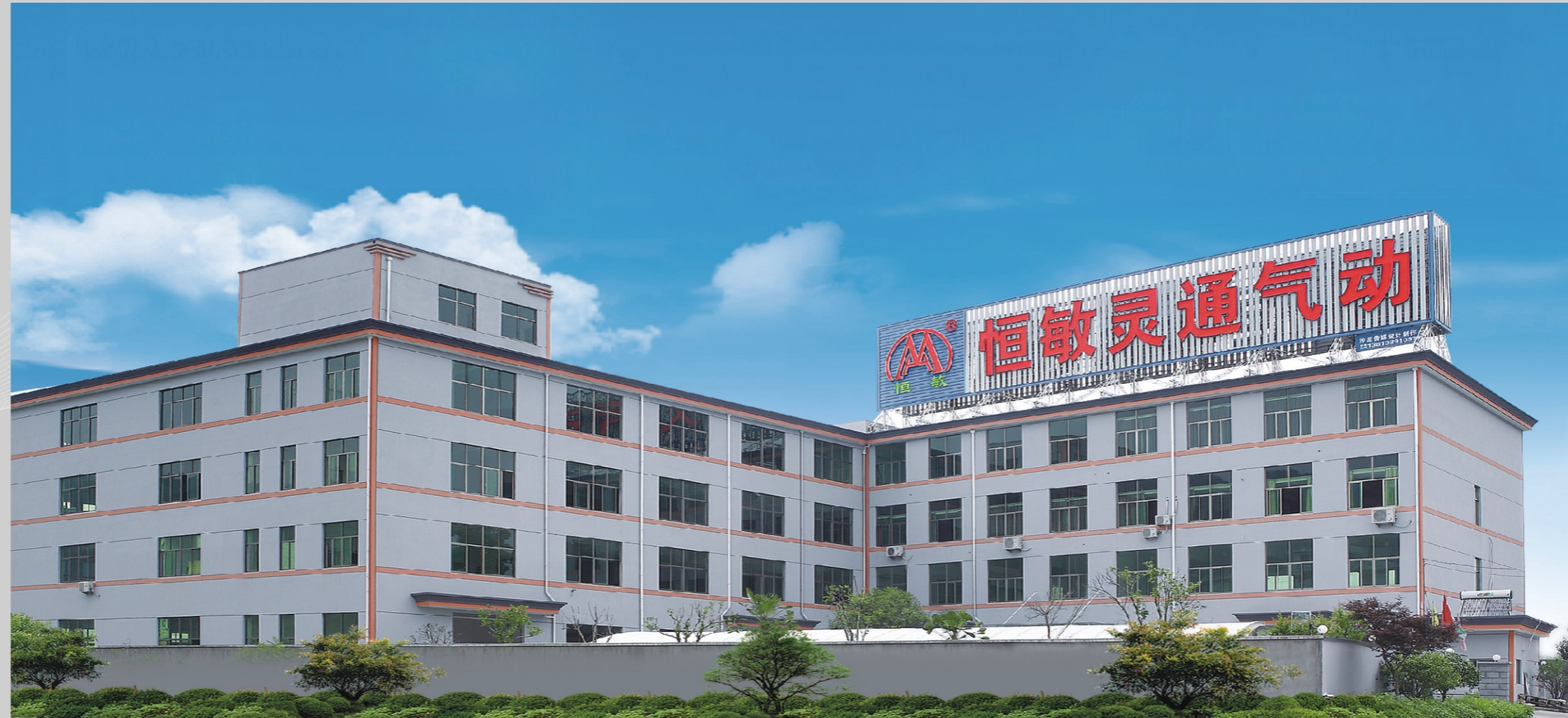



◎ 会议室 Meeting room

公司不断引进国外先进设备与技术，不断加强产品工艺、工装、设计与制造，取得了十分优良的效果，严格控制每一个关键的生产环节，不但提高了企业的技术水平，同时还保证了产品的质量。

We have got satisfactory accomplishments through introducing advanced equipment and technology, and improving the workmanship, device and production. Meanwhile, we strictly control every step of production to ensure the higher technological level of the company and the quality of products.



◎ 加工中心 / Processing center



◎ 进口精密车床  
Import precision lathe



◎ 进口精密车床  
Import precision lathe



◎ 装配中心  
Assembling centre



◎ 测试台 Test Board

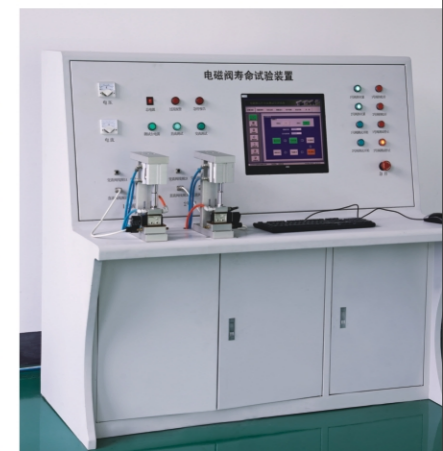

◎ 测试台 Test Board

## 快速测试连接器/Instant Threaded Connections

### AA® 订购代码/Ordering Code

<b>LT</b>	—	<b>KS</b>	—	<b>H</b>	—	<b>06</b>	—	<b>G</b>	—	<b>I</b>
公司名称 Company Name		系列 Series		操作方式 Operation Code H: 压柄式 H: Squeeze Lever V: 按钮式 V: Pneumatic Thumb Valve		接管口径 Port Size 06 : 1/8" 08 : 1/4" 10 : 3/8" 15 : 1/2" 20 : 3/4"		螺纹种类 Thread type G N:NPT		B: 使用压力 B: Pressure I : 低压 I : Low Pressure II : 高压 II : High Pressure

### AA® 规格/Specification

系列/Series	KSH/V-06	KSH/V-08	KSH/V-10	KSH/V-15	KSH/V-20
B口使用压力/B Pressure	I 型:0~1.6Mpa				
P口使用压力/P Pressure	II 型:0~34.5Mpa				
工作温度/Operating Temperature	0.6~1.0Mpa				
	-10~70℃ (但未冻结) / (Not Frozen)				



### AA® 外形尺寸图/Overall Dimension Drawing (mm)

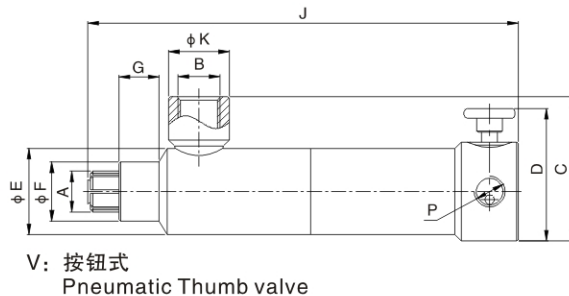
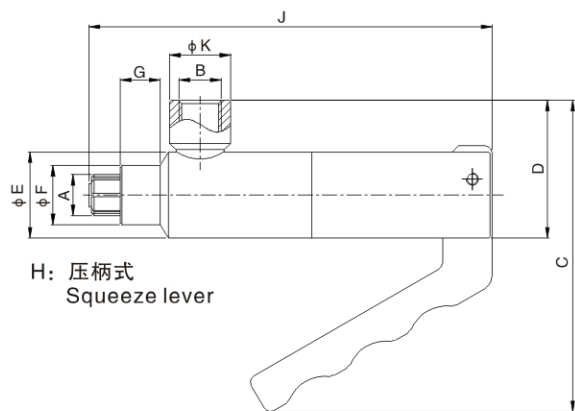

插入深度/Insertion Depth

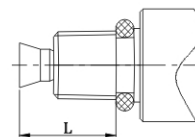

型号/Mode		A	B	C	D	E	F	G	K	J	I II		P	
													L	
KSH	06	1/8	1/8	94	36.5	27	16	12.5	15	122	8	14	—	
KSV				41.5	36.5					130.5			1/8	
KSH	08	1/4	1/4	101	43.5	27	18.5	12.5	19	127	9	17	—	
KSV				40.5	43.5					132.5			1/8	
KSH	10	3/8	1/4	99	47.5	32	22	9	19	127	9	17	—	
KSV				40.5	47.5					128.5			1/8	
KSH	15	1/2	3/8	112	59	36.5	28	7	23	134	10	19.5	—	
KSV				47	59					134			1/8	
KSH	20	3/4	1/2	122	66	44	34.5	7	28	148	12	21	1/8	
KSV				66	66					148			1/8	

## 直管快速连接器 Tube Connectors

### 订购代码/Ordering Code

**LT** — **KSZG** — **6**

公司名称 Company Name  
 系列 Series  
 直管外径 Straight pipe diameter  
 6  
 8  
 10



### 外形尺寸图/Overall Dimension Drawin(mm)

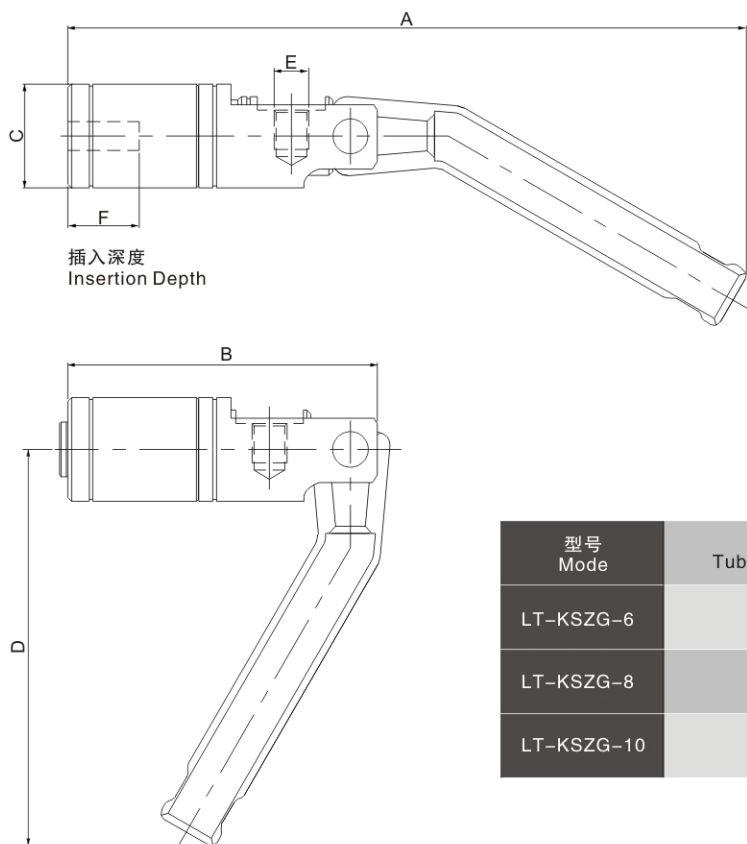

型号 Model	直管尺寸 Tube Size (± 0.25)	A	B	C	D	E	F
LT-KSZG-6	6	190	87	29	126	G1/8	22
LT-KSZG-8	8						
LT-KSZG-10	10						

### 规格/Specification

系列/Series	LT-KSZG-6	LT-KSZG-8	LT-KSZG-10
使用压力/Working Pressure(MPa)	0~6.5		
工作温度/Operating Temperature(°C)	-10~70°C(但未冻结/Not Frozen)		